



Pompe da drenaggio indicate per svuotamento di pozzi neri o cisterne, per giardinaggio; completamente in materiale anticorrosivo.

Drainage pump for emptying pits and cisterns, for gardening; completely constructed in anticorrosive material.

Bombas de drenaje indicadas para vaciar fosas sépticas o cisternas, para la jardinería; completamente de material anticorrosivo.

Pompes de drainage indiquées pour le vidage de fosses d'aisances ou citernes, pour le jardinage; entièrement en matériau anticorrosion.



DP 40



DP 60

**CARATTERISTICHE COSTRUTTIVE / CONSTRUCTION FEATURES
CARACTERÍSTICAS CONSTRUCTIVAS / CARACTÉRISTIQUES D'EXÉCUTION**

Corpo pompa	polipropilene
Pump body	polypropylene
Cuerpo bomba	polipropileno
Corps de pompe	polypropylène
Girante	
Impeller	Noryl®
Rodete	
Turbine	
Tenuta meccanica	doppia tenuta a labbro
Mechanical seal	double lip seal
Sello mecánico	doble sello
Garniture mécanique	double joint d'étanchéité à lèvres
Albero motore	acciaio AISI 416 con boccola in ceramica
Motor shaft	stainless steel AISI 416 with ceramic bush
Eje motor	acero AISI 416 con casquillo de cerámica
Arbre moteur	acier AISI 416 avec bague en céramique
Passaggio corpi solidi	
Passage of solids	Ø max 4 mm
Pajo de solidos	
Passage corps solides	
Profondità di immersione	
Depth of immersion	max 5 m
Profundidad inmersión	
Profondeur immersion	
Temperatura del liquido	
Liquid temperature	0 - 40 °C
Temperatura del líquido	
Température du liquide	
Cavo	
Cable	H07 RNF, 10 m
Cable	
Câble	
G	galleggiante float switch flotador flotteur
MOTORE / MOTOR / MOTOR / MOTEUR	
Motore 2 poli a induzione	3~ 230/400V-50Hz
2 pole induction motor	1~ 230V-50Hz
Motor de 2 polos a inducción	con termoprotettore with thermal protection
Moteur à induction à 2 pôles	con protección térmica avec protection thermique
Classe di isolamento	
Insulation class	F
Clase de aislamiento	
Classe d'isolation	
Grado di protezione	
Protection degree	IP68
Grado de protección	
Protection	

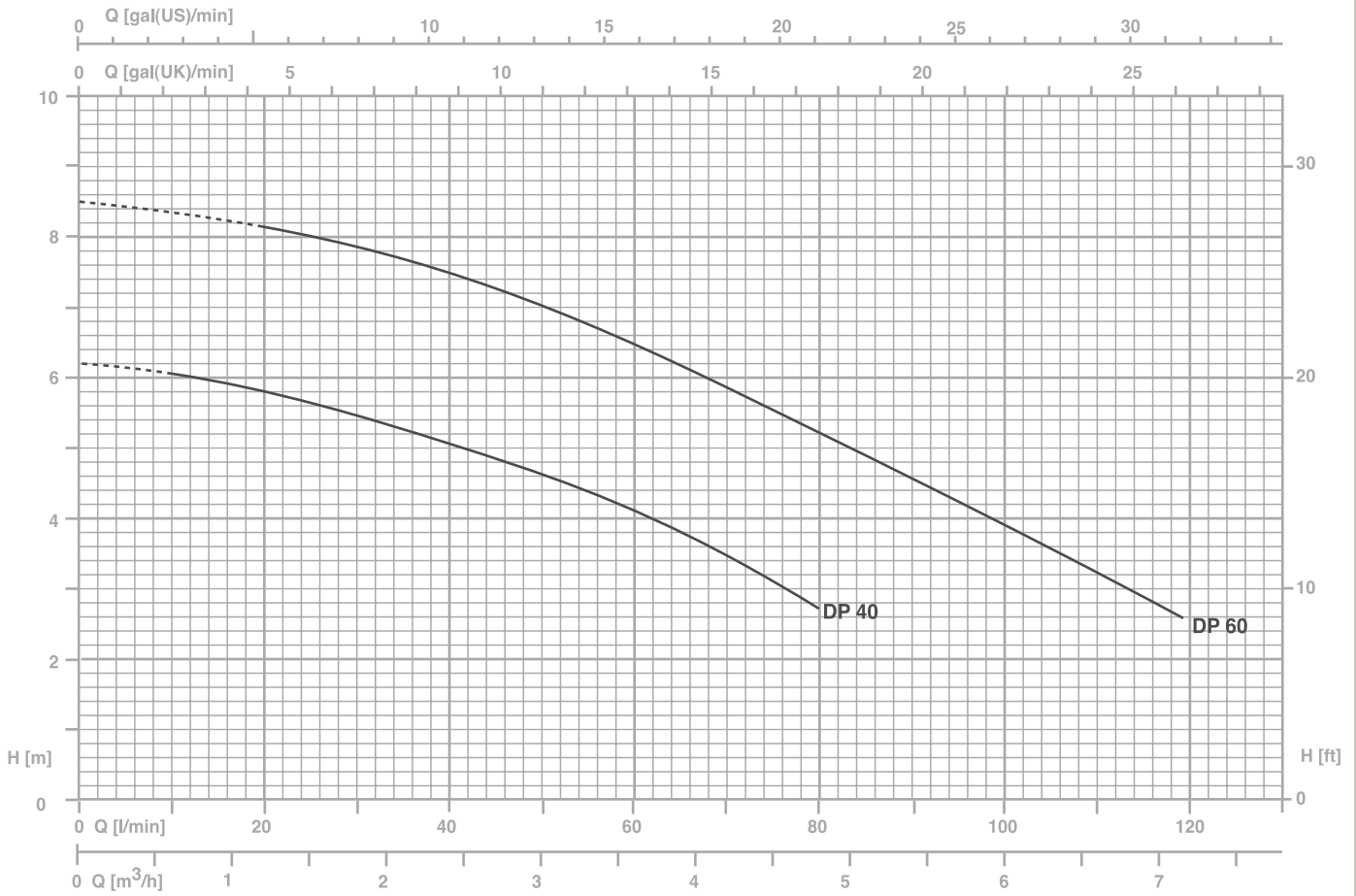

TYPE	W	AMPERE	Q (m³/h - l/min)							
		1~	0	1,2	2,4	3,6	4,8	6	7,2	
1~	W	1~	0	20	40	60	80	100	120	
		1x230 V 50 Hz	H (m)							
DP 40 G	200	1	6,1	5,7	5	4,2	2,5	-	-	
DP 60 G	400	2,1	8,5	8,1	7,6	6,7	5	3,9	2,6	

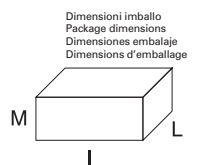
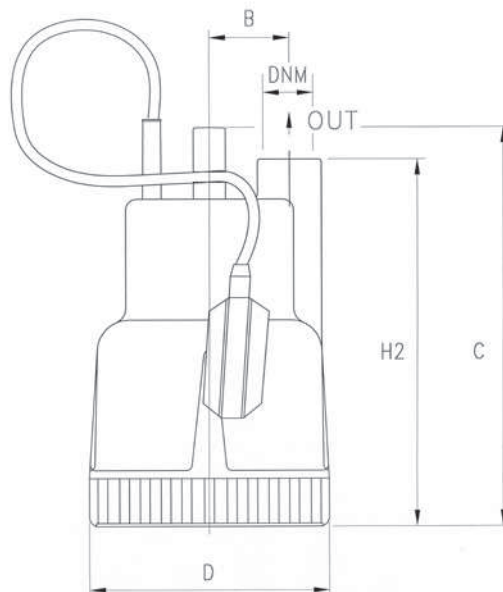

TYPE	DIMENSIONS (mm)								Kg
	B	C	D	H2	DNM	I	L	M	
DP 40 G	50	250	150	230	1" G	170	200	320	3.2
DP 60 G	50	250	150	230	1" G	170	200	320	4.2

DP/DPV



DP



DPV

Pompe da drenaggio indicate per svuotamento di pozzi neri o cisterne, per giardinaggio; completamente in materiale anticorrosivo; sono dotate d'inserto d'ottone nella bocca di mandata. Disponibili nella versione Vortex (DPV).

Drainage pump for emptying pits and cisterns, for gardening; completely constructed in anticorrosive material; brass insert on the delivery opening. Available in the version Vortex (DPV).

Bombas de drenaje indicadas para vaciar fosas sépticas o cisternas, para la jardinería; completamente de material anticorrosivo; están dotadas de inserción de latón en la boca de impulsión. Disponibles en la versión Vortex (DPV).

Pompes de drainage indiquées pour le vidage de fosses d'aisances ou citernes, pour le jardinage; entièrement en matériau anticorrosion; sont équipées d'un insert en laiton sur la bride de refoulement. Disponibles dans la version Vortex (DPV).



DP/DPV 80



DP/DPV 100

CARATTERISTICHE COSTRUTTIVE / CONSTRUCTION FEATURES CARACTERÍSTICAS CONSTRUCTIVAS / CARACTÉRISTIQUES D'EXÉCUTION

Corpo pompa	polipropilene
Pump body	polypropylene
Cuerpo bomba	polipropileno
Corps de pompe	polypropylène
Girante	
Impeller	Noryl®
Rodete	
Turbine	
Tenuta meccanica	doppia tenuta a labbro
Mechanical seal	double lip seal
Sello mecánico	doble sello
Garniture mécanique	double joint d'étanchéité à lèvres
Albero motore	acciaio AISI 416 con boccia in ceramica
Motor shaft	stainless steel AISI 416 with ceramic bush
Eje motor	acero AISI 416 con casquillo de cerámica
Arbre moteur	acier AISI 416 avec bague en céramique
Passaggio corpi solidi	
Passage of solids	Ø max 7 mm (DP)
Pajo de solidos	Ø max 15 mm (DPV)
Passage corps solides	
Profondità di immersione	
Depth of immersion	max 5 m
Profundidad inmersión	
Profondeur immersion	
Temperatura del liquido	
Liquid temperature	0 - 40 °C
Temperatura del liquido	
Température du liquide	
Cavo	
Cable	H07 RNF, 10 m
Cable	
Câble	
G	galleggiante float switch flotador flotteur

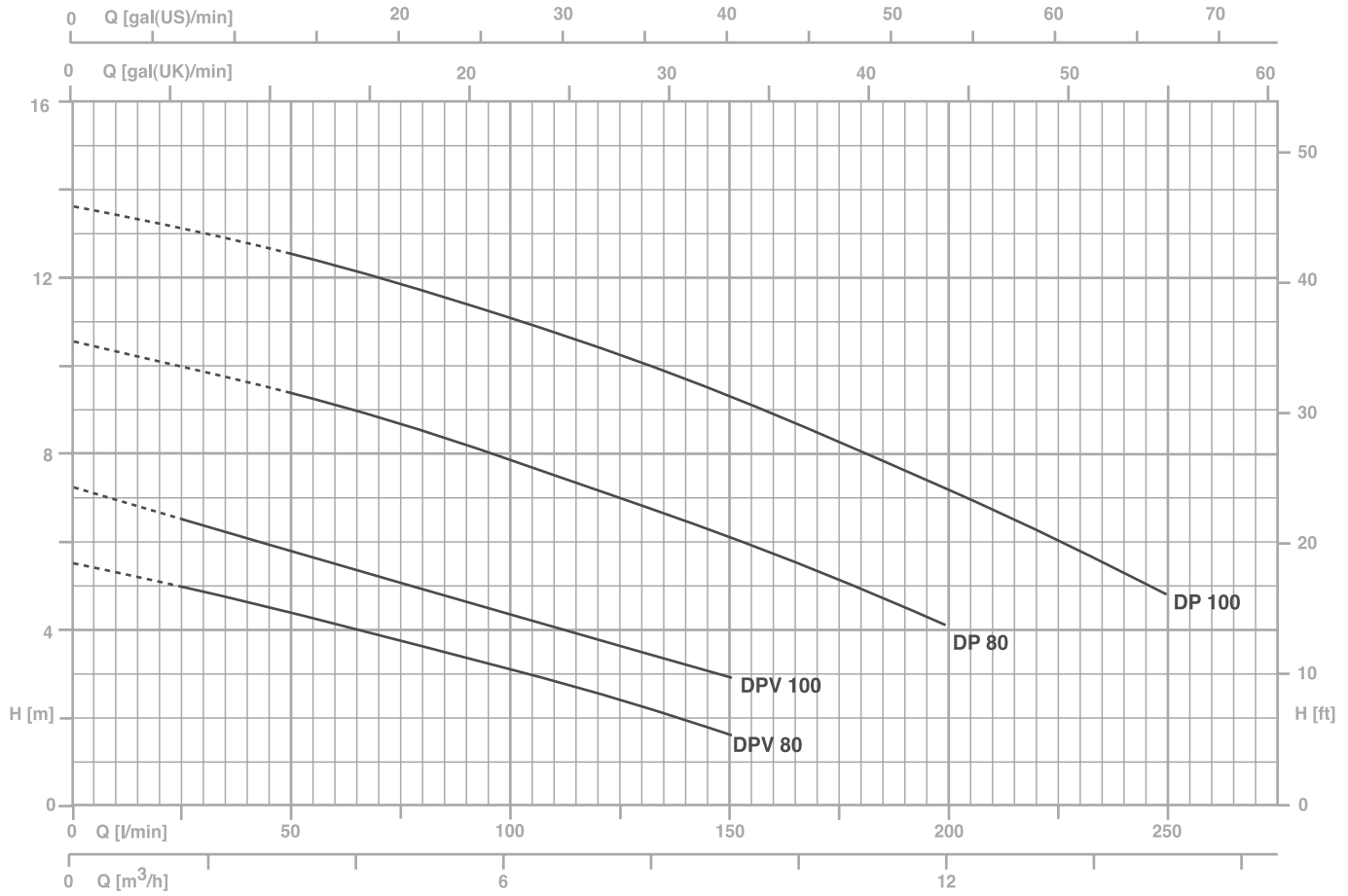

MOTORE / MOTOR / MOTOR / MOTEUR

Motore 2 poli a induzione	3~ 230/400V-50Hz
2 pole induction motor	1~ 230V-50Hz
Motor de 2 polos a inducción	con termoprotettore with thermal protection
Moteur à induction à 2 pôles	con protezione termica avec protection thermique
Classe di isolamento	
Insulation class	F
Clase de aislamiento	
Classe d'isolation	
Grado di protezione	
Protection degree	IP68
Grado de protección	
Protection	

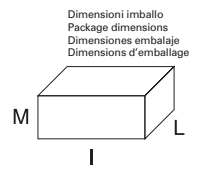
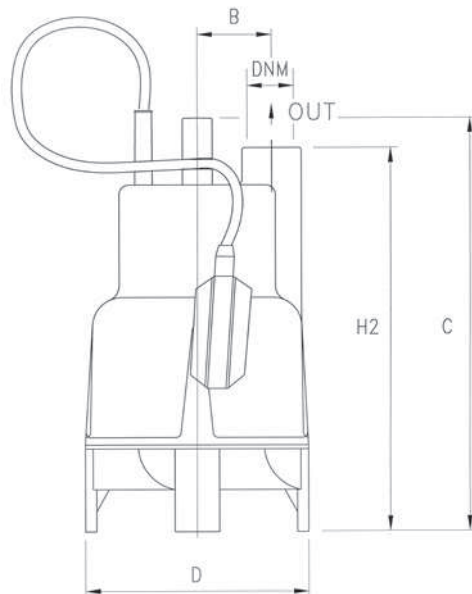

TYPE		W	AMPERE		Q (m³/h - l/min)					
1~	3~		1~	3~	0	3	6	9	12	15
			1x230 V 50 Hz	3x400 V 50 Hz	0	50	100	150	200	250
		H (m)								
DP 80 G	DPT 80	800	3,7	1,8	10,3	9,1	7,8	6,3	4	-
DP 100 G	DPT 100	1050	5,1	2,3	13,3	12,2	10,9	9,3	7,3	4,5
DPV 80 G	DPVT 80	500	2,6	1,2	5,4	4,2	2,9	1,7	-	-
DPV 100 G	DPVT 100	750	3,8	1,7	7,4	5,8	4,7	2,7	-	-



TYPE	DIMENSIONS (mm)								
	B	C	D	H2	DNM	I	L	M	
DP 80 G	55.5	296	176	276	1" 1/4 G	185	230	310	8.5
DPV 80 G	55.5	331	176	310	1" 1/4 G	185	230	345	8.5
DP 100 G	55.5	296	176	276	1" 1/4 G	185	230	310	10
DPV 100 G	55.5	331	176	310	1" 1/4 G	185	230	345	10